







LINK Large Heads

CE 0482

Explanation of Pictograms			
	Manufacturer		Article number
	Material (number)		Product meets the applicable requirements, which are regulated in the EU harmonization legislation for the affixing of the CE marking.

LINK Large Heads

System Description

02 LINK Large Heads

Surgical Technique

03 Preoperative Planning

04 Practical Steps

06 Surgical Approaches

07 Surgical Technique

Implants

10 LINK Large Heads

Instruments

11 Instrument Set for LINK Large Heads

Accessories

12 X-ray Templates

13 Literature

13 Additional Prostheses Systems

14 **Indications/Contraindications**

Important Information

LINK Large Heads

LINK Large Head prostheses are available as an alternative to the Vario-Cup system. The Large Head prostheses are manufactured using a tried and trusted cobalt chromium-molybdenum alloy. A high gloss polished surface is provided for articulation in the bony acetabulum.

Large Head prostheses are available with external diameters ranging from 38 to 60 mm so that all patients can be given appropriate models.

Note

LINK prosthesis systems are manufactured to ensure precise intercompatibility so that appropriate components can be combined without incurring problems of function. They cannot be used with hip components made by other manufacturers.

Advantages

- Natural range of movement is restored*

** Design Dossier: W.LINK – Internal document.*

Preoperative Planning

Preoperative planning is conducive towards optimal surgical outcomes by ensuring the most appropriate implants are selected for the patient. The key objectives involved are the correct positioning of the central rotational point of the hip, correct leg length and finally preservation or restoration of sufficient soft tissue tension by avoiding medialization of the femur.

Achieving anatomically appropriate CCD or neck angle and head-neck length are of paramount importance. Hip stems with different CCD angles are offered by LINK as well as femoral heads with up to four head-neck lengths affording the surgeon great flexibility.

Planning should ideally be based on two X-rays: an AP film of the pelvis and a mediolateral X-ray of the hip in question. When performing the pelvic X-ray it is important to ensure that:

1. Both femurs are shown in their entirety.
2. The femurs are straight and parallel and, if possible, internally rotated approximately 5° in that position.
3. Key landmarks needed for planning are visible: the inferior margins of the obturator foramen and of the acetabular teardrop.

When evaluating the X-rays, it is important to factor in any magnification incurred. Two factors are decisive:

- 1) Focal distance
Focal spot X-ray tube $\leftarrow x \rightarrow$ Film cassette A focal distance of 100 cm gives magnification of about 10%.
- 2) Object film distance
Femoral axis $\leftarrow x \rightarrow$ Film cassette

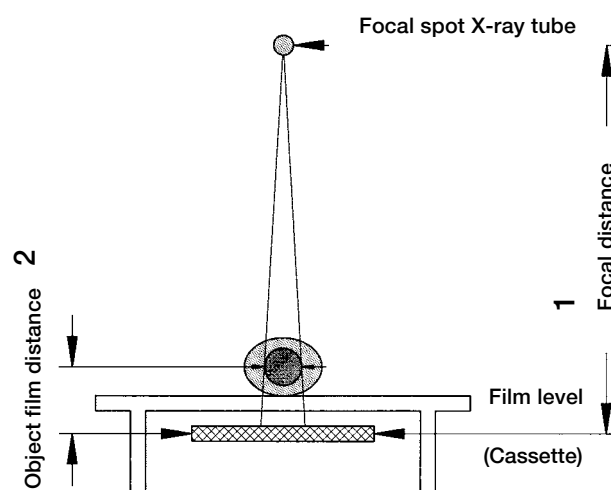

The choice of implant should ensure that the Large Head prostheses, fills the acetabulum completely.

When these implants are used it is essential that there is no arthritis in the acetabulum and that no injuries are found during implantation.

Practical Steps

First, geometrical measurements are taken on the basis of the pelvic radiograph. This can be done on the X-ray directly (Fig. 2), but it is better to trace the skeletal contours onto tracing paper (Fig. 3).

A horizontal reference line is drawn along the inferior margins of the obturator foramen, followed by a vertical reference line along the sacral crest, ideally passing through the center of the pubic symphysis.

From these two lines, the center of rotation, difference in leg length, left/right femoral distance, distance between the left/right muscle T lever arms, etc. are defined and marked on the tracing paper.

This provides an overview and landmarks for orientation during surgery, e.g. transfer of dimensional reference to the bone. It must always be remembered that the measurements on the radiograph include a magnification effect that must be allowed for if the measurements are transferred to bone. If the magnification is 10%, measurements taken from the radiograph must be divided by 1.1. So, for example, 60 mm apparent \div 1.1 = 54.5 mm actual measurement. The same applies for other magnifications: e.g. at 15% magnification a 60 mm apparent measurement gives 60 mm \div 1.15 = 52.2 mm actual measurement.

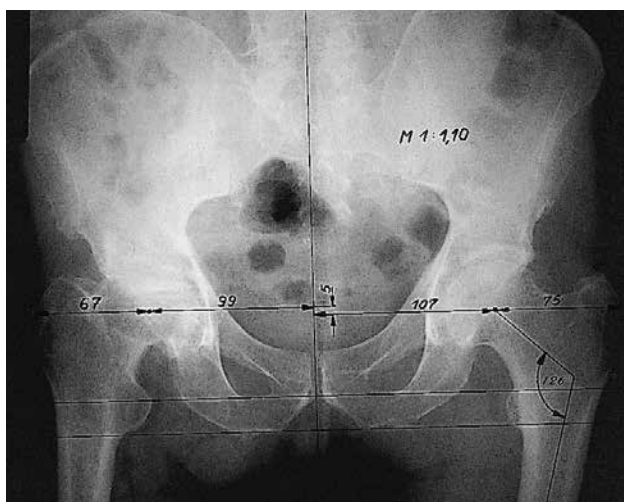

Fig. 2

Once the dimensions have been entered, the templates are used to select the best implant components for the particular case. The template is positioned on the radiograph such that the center of rotation coincides with the anatomical center of rotation as determined in the drawing. The implant components selected should correct any anatomical insufficiencies derived from the measurements.

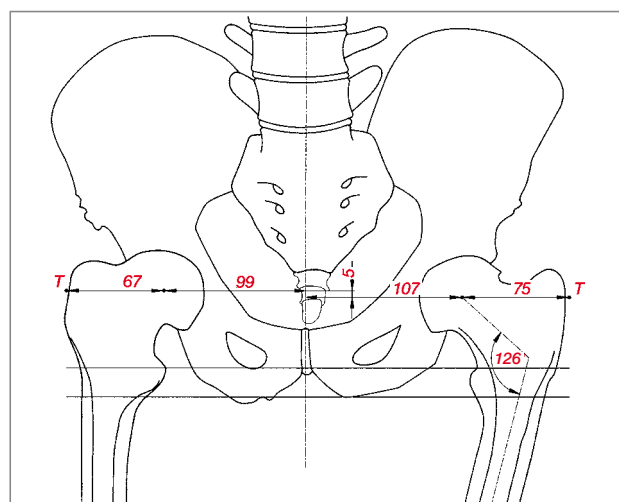

Fig. 3

In addition to pelvic radiograph, the mediolateral radiograph is used to determine the stem shape and size of the femoral prosthesis as seen from the lateral view.

The planned result becomes clearer when the transparent sheet with the outlined skeletal contours, measurements, and sketched-in position of the acetabular cup is placed on top of the radiograph and adjusted so that the femur in the radiograph is in the desired outcome position in relation to the drawing of the pelvis. This position is then traced onto the tracing paper, preferably in a different color (Fig. 4).

The differences on the tracing paper, e.g. actual and planned positions of the femur, provide the visual overview required for surgical planning and precise selection of the implant components using the X-ray templates or, if necessary, for custom-design implants (Fig. 5).

Materials required:

1. Tracing paper
2. Transparent ruler, 1:1
3. Transparent protractor
4. Transparent radius/hole template
 \varnothing 24 to 58 mm, in 2 mm increments

Note

Preoperative planning may be time-consuming but it provides intraoperative guidance and can enhance the final result.

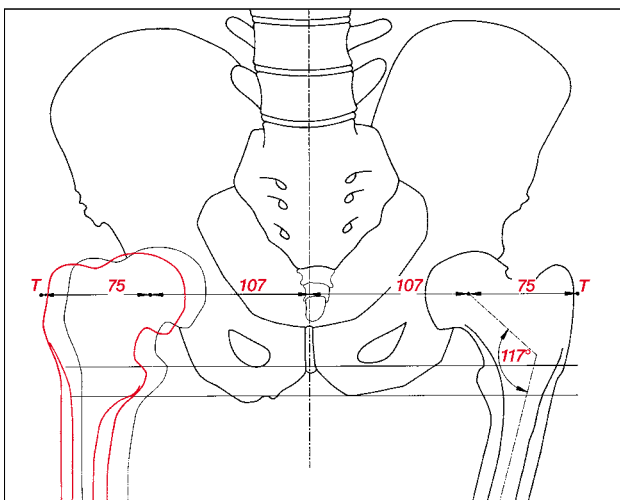

Fig. 4

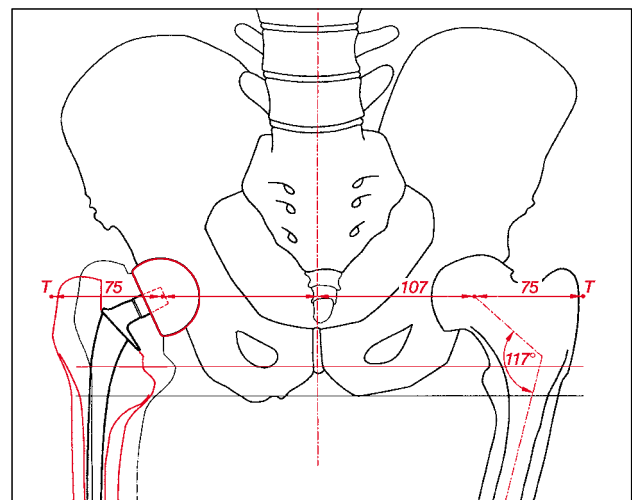

Fig. 5

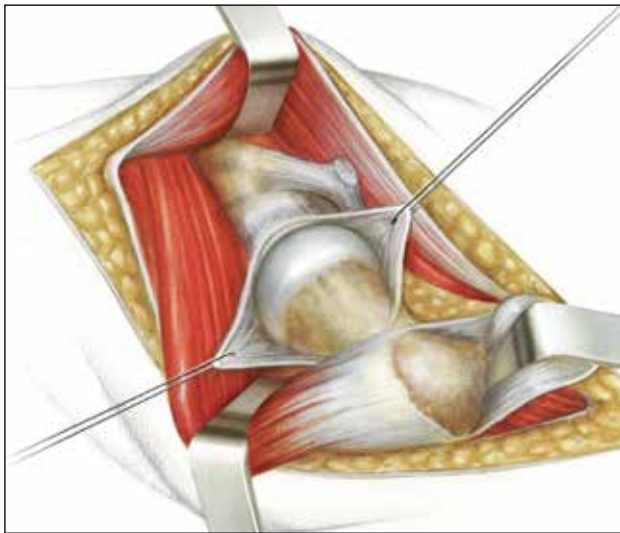

Fig. 6 Pre-op x-ray



Fig. 7 Post-op x-ray

Surgical Approaches



(A) **Watson Jones**

The choice depends on the surgeon's experience and his/her decision based on the individual situation.

The following approaches are usual:

- antero-lateral – **Watson Jones** (A)
- direct lateral – **Hardinge** (B)
- postero-lateral – **Moore** (C)

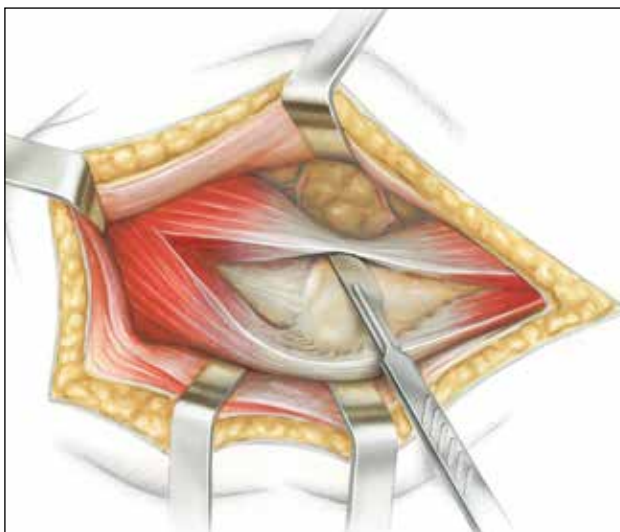

(B) **Hardinge**

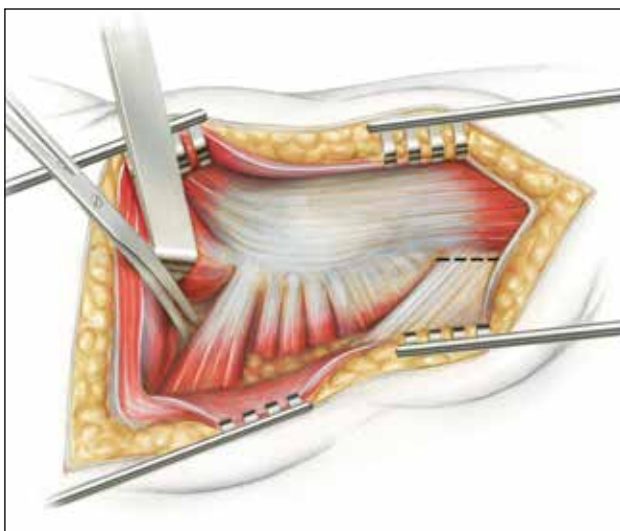
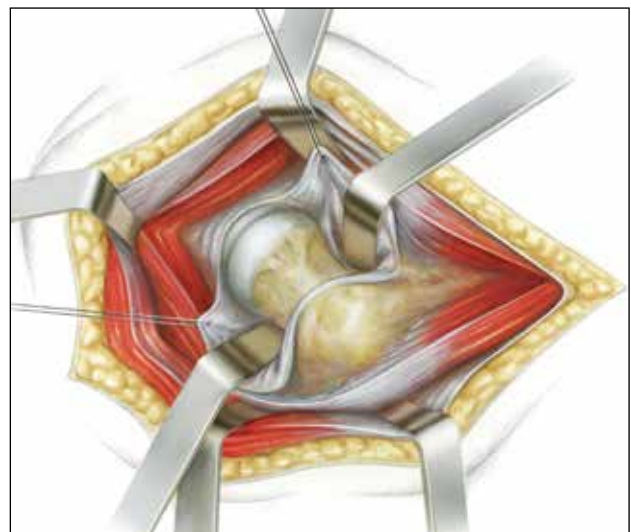

(C) **Moore**

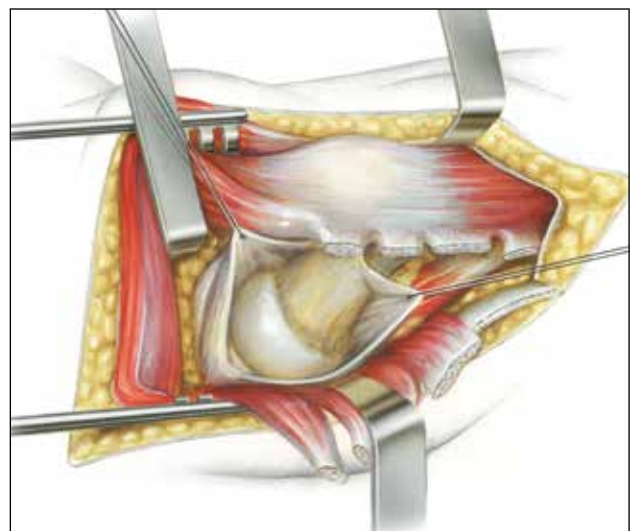

Surgical Technique

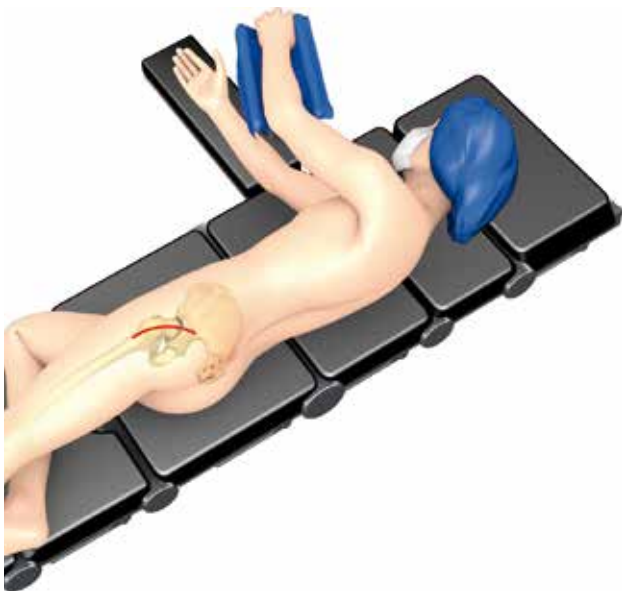

Fig. 1

The patient is placed in the lateral decubitus position. The approach may be used depending on the surgeon's experience. Possibilities are shown on page 06.



Fig. 2

The femoral head is luxated using internal rotation and 90° flexion of the femur.

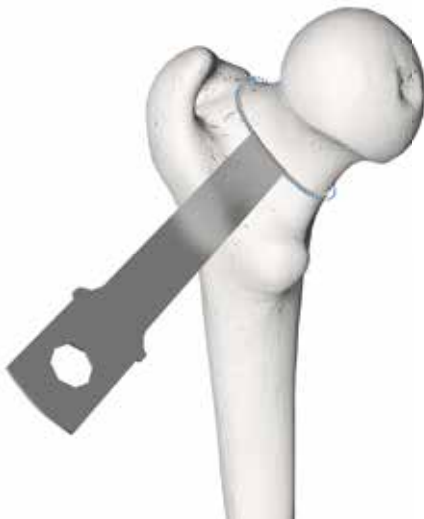

Fig. 3

The femur (resection of the femoral head) is prepared according to the surgical technique of the used LINK Hip stem.



Fig. 4

The acetabulum is exposed after femoral head resection.

Note

Surgical techniques of the different prosthesis-stems are described in detail in separate catalogues for each individual system (see page 13; Additional Hip Systems).



Fig. 5

Use the Plastic Trial Heads to confirm the head size pre-operatively planned. The Trial Heads can be attached to the Handle to allow easy access of the Trials to the acetabulum.

Note

Osteophytes at the acetabulum that could limit the range of motion (ROM) should be removed.



Fig. 6

A trial reduction can be performed to check the range of motion of the Large Head. Assemble the Trial Sleeve and chosen Trial Head on the implanted stem for a trial reduction.



Fig. 7

Place the Large Head on the carefully cleaned taper of the stem. Fix the Large Head with a light tap on the Impactor.

Note

The taper is to be connected in dry and clean condition.



Fig. 8

Final reduction

Note

The articulating surfaces are not to be damaged during reduction.

LINK Large Heads

MAT CoCrMo alloy

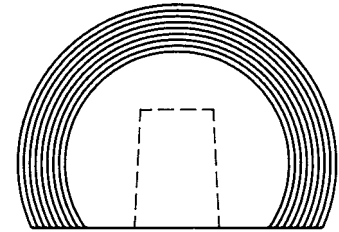
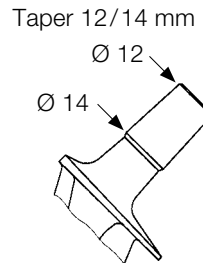

Head Ø 38 - 60 mm

REF	Head Ø mm
126-838	38
126-840	40
126-842	42
126-844	44
126-846	46
126-848	48
126-850	50
126-852	52
126-854	54

REF	Head Ø mm
99-0150/31	56
99-0150/32	58
99-0150/33	60

REF	Head Ø (mm)	Neck length	Neck length (mm)
99-0709/50	38	short	-4
99-0709/54	38	medium	0
99-0709/58	38	long	+4
99-0710/50	40	short	-4
99-0710/54	40	medium	0
99-0710/58	40	long	+4
99-0711/50	42	short	-4
99-0711/54	42	medium	0
99-0711/58	42	long	+4

106-005/00 Instrument Set, complete, 575 x 275 x 100 mm

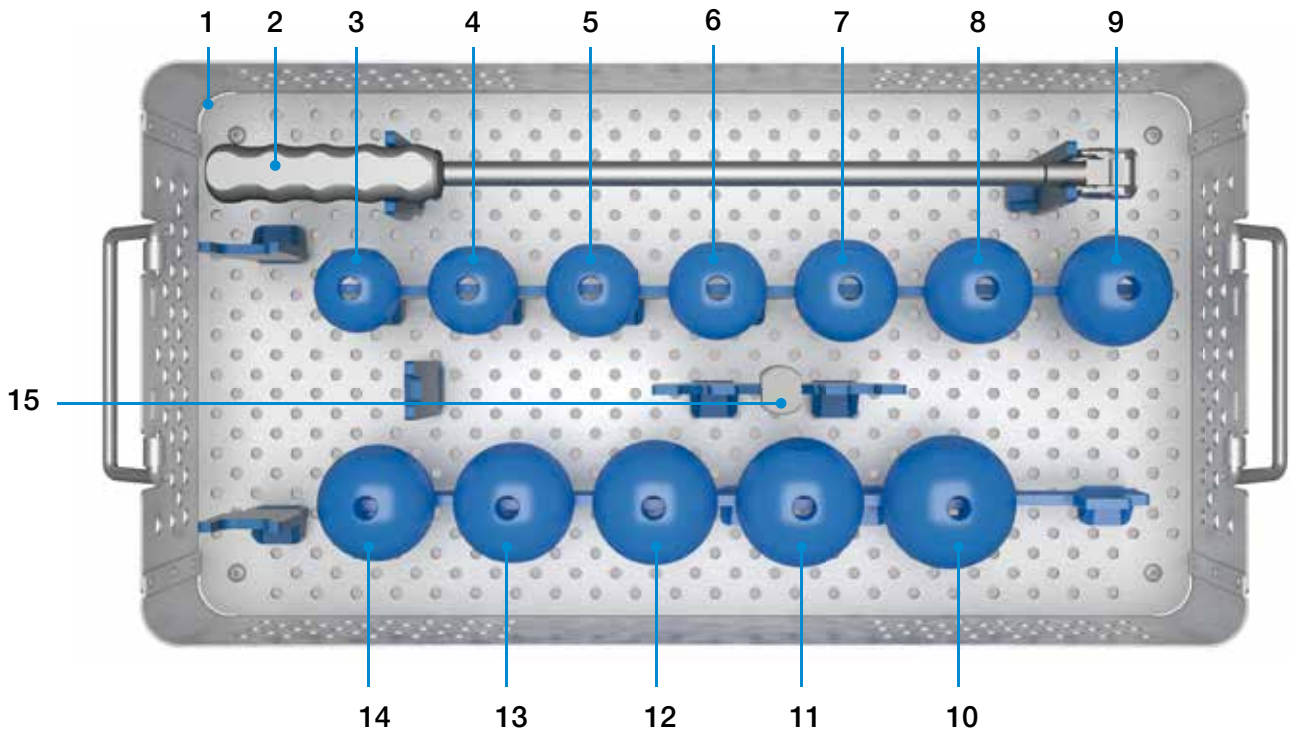

	REF	Description	
1	106-004/00	Tray, empty, 575 x 275 x 100 mm, perforated stainless steel	
2	106-007/00	Handle for Cup Trial	
3	106-010/38	Plastic Trial Head	Ø 38 mm
4	106-010/40	Plastic Trial Head	Ø 40 mm
5	106-010/42	Plastic Trial Head	Ø 42 mm
6	106-010/44	Plastic Trial Head	Ø 44 mm
7	106-010/46	Plastic Trial Head	Ø 46 mm
8	106-010/48	Plastic Trial Head	Ø 48 mm
9	106-010/50	Plastic Trial Head	Ø 50 mm
10	106-010/52	Plastic Trial Head	Ø 52 mm
11	106-010/54	Plastic Trial Head	Ø 54 mm
12	106-010/56	Plastic Trial Head	Ø 56 mm
13	106-010/58	Plastic Trial Head	Ø 58 mm
14	106-010/60	Plastic Trial Head	Ø 60 mm
15	106-020/05	Plastic Trial Sleeve for LINK Large Heads	

X-ray Templates

130-910/01

X-ray templates for LINK Large Heads

Outer Ø 38-60 mm, taper 12/14, set of 2 sheets

110% actual size for:

126-838 to 126-854, 99-0150/31 to 99-0150/33, 99-0709/50 to 99-0709/58, 99-0710/50 to 99-0710/58 and 99-0711/50 to 99-0711/58

Instructions for Cleaning and Maintenance

Specific instructions for instruments are available on request from customer@linkhh.de

Literature

Leonardsson Q, Garellick G, Karrholm J, Akesson K, Rogmark C.

Changes in implant choice and surgical technique for hemiarthroplasty. 21,346 procedures from the Swedish Hip Arthroplasty Register 2005-2009.; Acta Orthop. 2012;83(1): 7-13

Leonardsson O, Karrholm J, Akesson K, Garellick G, Rogmark C.

Higher risk of reoperation for bipolar and uncemented hemiarthroplasty.; Acta Orthop. 2012;83(5): 459-66

Kanto K, Sihvonen R, Eskelinen A, Laitinen M.

Uni- and bipolar hemiarthroplasty with a modern cemented femoral component provides elderly patients with displaced femoral neck fractures with equal functional outcome and survivorship at medium-term follow-up. Arch Orthop Trauma Surg. 2014; 134(9): 1251-9

Swedish Hip Arthroplasty Register, Annual Report 2017; www.shpr.se

Additional Prosthesis Systems

The **LINK Large Heads** can be combined with other LINK Hip Prosthesis Systems:



For more information please register for our LINK Media Library (linkorthopaedics.com)

Indications and Contraindications: LINK Large Heads
General Indications
Mobility-limiting diseases, fractures or defects of the hip joint or proximal femur which cannot be treated by conservative or osteosynthetic procedures
Indications
Necrosis of the femoral head ^{1,2}
Femoral neck fractures ¹
Contraindications
Acute and chronic infections, local and systemic insofar as they compromise the successful implantation
Allergies to (implant) materials
Insufficient/inadequate bone mass- or quality which prevents a stable anchorage of the prosthesis
Acetabulum fracture

1 for older, less mobile or immobile patients

2 excluding End Stage Osteonecrosis

Please note

These indications/contraindications refer to standard cases. The ultimate decision on whether or not an implant is suitable for a patient must be made by the surgeon based on his/her individual analysis and his/her experience.

Please note the following regarding the use of our implants:

1. Choosing the right implant is very important.

The size and shape of the human bone determines the size and shape of the implant and also limits the load capacity. Implants are not designed to withstand unlimited physical stress. Demands should not exceed normal functional loads.

2. Correct handling of the implant is very important.

Under no circumstances should the shape of a finished implant be altered, as this shortens its life span. Our implants must not be combined with implants from other manufacturers. The instruments indicated in the Surgical Technique must be used to ensure safe implantation of the components.

3. Implants must not be reused.

Implants are supplied sterile and are intended for single use only. Used implants must not be used again.

4. After-treatment is also very important.

The patient must be informed of the limitations of the implant. The load capacity of an implant cannot compare with that of healthy bone!

5. Unless otherwise indicated, implants are supplied in sterile packaging.

Note the following conditions for storage of packaged implants:

- Avoid extreme or sudden changes in temperature.
- Sterile implants in their original, intact protective packaging may be stored in permanent buildings up until the "Use by" date indicated on the packaging.
- They must not be exposed to frost, dampness or direct sunlight, or mechanical damage.
- Implants may be stored in their original packaging for up to 5 years after the date of manufacture. The "Use by" date is indicated on the product label.
- Do not use an implant if the packaging is damaged.

6. Traceability is important.

Please use the documentation stickers provided to ensure traceability.

7. Further information on the material composition is available on request from the manufacturer.

Follow the instructions for use!

Waldemar Link GmbH & Co. KG, Hamburg

All content in this catalog, including text, pictures and data, is protected by law. Every instance of use, whether in part or in whole and which is not permitted by law, is subject to our prior consent. In particular, this applies to the reproduction, editing, translation, publishing, saving, processing, or passing on of content stored in databases or other electronic media and systems, in any manner or form. The information in the catalogs is solely intended to describe the products and does not constitute a guarantee.

The Surgical Technique described has been written to the best of our knowledge and belief, but it does not relieve the surgeon of his/her responsibility to duly consider the particularities of each individual case.

Products shown in this document may not be available in your country. The product availability is subject to the approval and/or registration regulations of the respective country. Please contact Waldemar Link GmbH & Co. KG if you have questions about the availability of LINK products in your country.

Waldemar Link GmbH & Co. KG and/or other corporate affiliated entities own, use or have applied for the following trademarks in many jurisdictions: LINK, BiMobile, SP II, Modell Lubinus, E-Dur, EndoDur, T.O.P. II, BetaCup, CombiCup PF, CombiCup SC, CombiCup R, MobileLink, C.F.P., LCU, SP-CL, LCP, MIT-H, Endo-Model, Endo-Model SL, MP, MEGASYSTEM-C, GEMINI SL, SPAR-K, LCK, Link OptiStem, HX, TiCaP, X-LINKed, PorAg, LINK PorEx, BiPorEx, PorEx-Z, TrabecuLink, Tilastan, customLINK, RescueSleeve, Stactip, VACUCAST.

Other trademarks and trade names may be used in this document to refer to either the entities claiming the marks and/or names or their products and are the property of their respective owners.

