







MP Reconstruction System

Uncemented & Cemented B

CE 0482

Explanation of Pictograms			
	Manufacturer		Article number
	Material number		Product meets the applicable requirements, which are regulated in the EU harmonization legislation for the affixing of the CE marking.

MP Reconstruction System

Uncemented & Cemented B

02 **System Overview**

Surgical Technique

- 03 Preoperative Planning
- 05 Surgical Technique, uncemented
- 14 Surgical Technique, cemented

Implants

- 17 Hip Prosthesis Stems, uncemented
- 18 Hip Prosthesis Stems, cemented
- 19 Neck Segments
- 20 Spacers and Expansion Bolts
- 21 Compatibility between Neck Segments, Proximal Spacers and Expansion Bolts

Instruments

- 22 MP General Instruments
- 23 MP Modular Basic Instruments
- 24 MP Reamers Core Lengths
- 26 MP Modular 160 mm
- 27 MP Reamers Long Stems
- 29 MP Reamers 330 mm
- 30 MP Modular Cemented Stems
- 31 Extraction Instruments

Accessories

- 32 X-ray Templates, Cleaning and Care Instructions

Literature

- 33 Reprints
- 34 Additional Literature

35 **Notes**

Important information

Hip Prosthesis Stems, uncemented

MAT Tilastan-S (TiAl6V4 alloy)

160 - 210 mm - Ø12 mm

160 - 330 mm - Ø14, 16, 18, 20, 22.5, 25 mm

Expansion bolts

41 mm and 61 mm

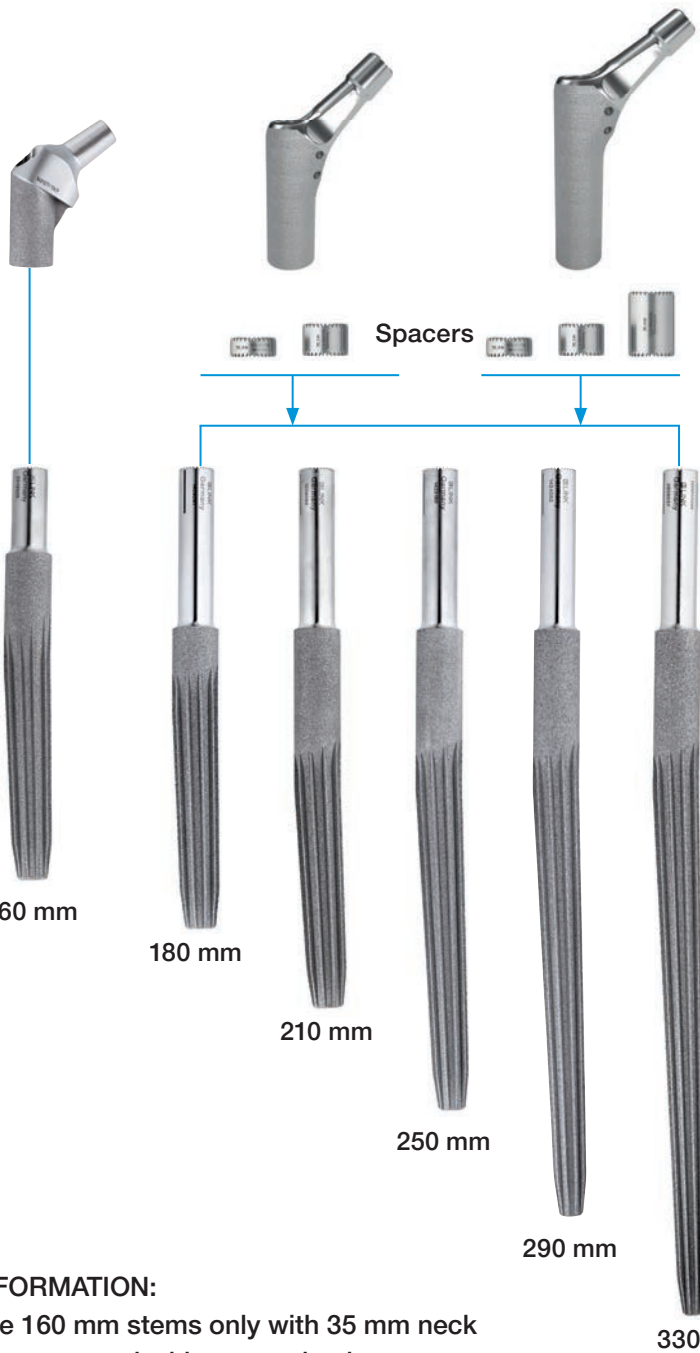

Neck segments

Standard

35 mm: CCD 126° and 135°

Slim

45 mm and 65 mm:
CCD 126°, 131° and 136°

Defect Reconstruction

45 mm and 65 mm: CCD 126°
and 131°

with suture holes Standard
35 mm: CCD 126°

35 mm neck segments cannot be used with proximal spacers

Hip Prosthesis Stems, cemented

MAT EndoDur-S (CoCrMo alloy)

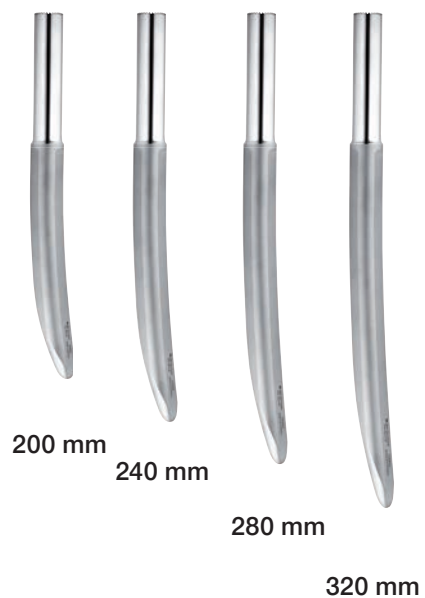

INFORMATION:

Use 160 mm stems only with 35 mm neck segments and without proximal spacers.

Do not use 210 mm / Ø12 mm stems with proximal spacers.

The MP Reconstruction System is for uncemented use. Only cemented labeled modular stems are indicated for cemented use.

Preoperative Planning



Templating aids as a first orientation in terms of implant choice and implant positioning. Planning templates are available for this purpose (Fig. 1).

The templating should be performed using high-quality AP and ML X-rays. Each X-ray should be large enough to apply the whole template.

Choice of implant sizes and types

As general rule, the prosthesis stem should be measured in such a way that positive-fit anchoring of the prosthesis is created over a sufficient length in vital bone. To this end, it is necessary to make allowance for reaming of the femoral canal. In order to restore the proper offset and center of rotation, the acetabular cup center of rotation is matched with the desired head center of rotation of the neck segment. The MP Reconstruction System offers three offsets with different CCD angles.

In-situ implants and the bone cement must be completely removed before implanting a MP Reconstruction System.

Preoperative planning supports optimal surgical outcomes by ensuring the most appropriate implants are selected for the patient. The key objectives are to correctly position the central rotational point of the hip, to achieve the correct leg length and finally preserve or restore sufficient soft tissue tension by avoiding medialization of the femur.

INFORMATION:

Templating is an important element of the preoperative planning. However, final decisions regarding implant choice and fit should be made intra-operatively to ensure appropriate leg length and joint stability.

Standing, weight bearing X-rays are recommended.

Both an AP and a lateral X-rays should be used to determine the required implant sizes.

Account for pelvic tilt to ensure correct positioning of the implants.

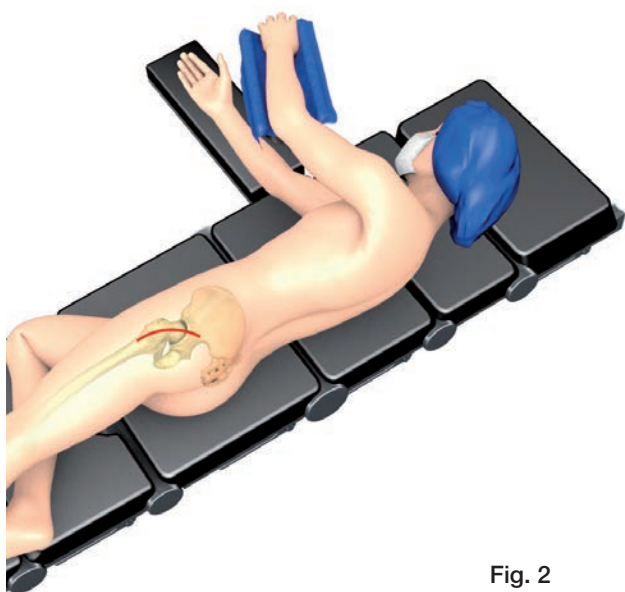

Fig. 2

Patient positioning / Surgical approaches

The surgeon is free to choose the surgical approach on the basis of their experience and judgment, and according to the specific situation. The following illustration shows the visualization with a posterior approach and with the patient in the lateral position (Fig. 2).

The surgical instructions below for restoring a damaged hip joint using the MP Reconstruction System depict an idealized surgical situation. However, every procedure has individual particularities, and the surgeon decides during the surgery which method can be expected to achieve the most success in each case.



Fig. 3

Opening

After careful removal of the previous implant and any associated cement, the greater trochanter and proximal femur are cleared with the Proximal Start Reamer, in order to allow easy, axial access into the femoral canal (Fig. 3).



Preparation of the femoral canal

Reamers are chosen according to the planned hip prosthesis stem length. Reaming must be performed by hand. Assemble the reamer with the reamer driver adapter and T-handle as shown (Fig. 4).

Fig. 4



Start with a reamer at least two sizes smaller than the preoperatively planned stem diameter. Carefully ream progressively until adequate endosteal engagement is achieved. The stem implant size should match final reamer size in order to obtain the desired press-fit of the implant. Care should be taken that the reamer is always oriented straight down into the femoral canal to avoid varus positioning (Fig. 5).

CAUTION:

Care should be taken to avoid fracture of the greater trochanter. If reaming on power, start the reamer before touching the bone, in order to decrease the risk of fracture.

Fig. 5



Fig. 6

The depth of reaming should be determined by the preoperative planning. Two lines on the reamer driver adapter are used for orientation. The upper mark “T” indicates the centre of rotation of the seated stem construct with no spacers and +0 mm head. This mark is oriented at the top of the greater trochanter. The lower mark “C” indicates the proximal end of the seated implant stem. This line should be at the proximal end of the lesser trochanter (calcar region) (Fig. 6).

The +10 mm, +20 mm and +30 mm marks on the adapter can be used as visual aids, in case spacers are used. The procedure can now be continued following two options.

Option 1: Trialing off the reamer (optional)

Option 2: Impaction of the implant stem

CAUTION:

In cases of weak bone or an extended trochanteric osteotomy, reaming to the “T” or “C” line is recommended. If the proximal bone is completely intact, reaming to the 10 mm mark at the calcar (“C”) or trochanter (“T”) is recommended to avoid the risk of the stem sitting to proud.

If a 160 mm stem is used, please consider page 13 Implantation of 160 mm stems.

Option 1: Trialing off the reamer

If desired, a trial reduction off the reamer can be conducted to obtain an early indication of the leg length. Disconnect the reamer adapter and T-handle from the reamer to trial off the modular reamer. Three proximal body trials are available to replicate the three different offset versions. There is no change in leg length between the different offset versions.

The short neck segments (length 45 mm) can only be combined with +5 mm and +10 mm spacers, if necessary. If the proximal cavity is not cleared enough or the greater trochanter is overhanging it might be necessary to remove bone to fit the trial necks. This can be done with a rongeur.

To assemble the trial neck onto the reamer, the trial neck is slid over the rod (Fig 7a) until the desired height is achieved. Fix the neck at the desired height and anteversion by tightening the screw in the trial neck with the torque-limiting screwdriver (Fig 7b).



Fig. 7a

Fig. 7b

A plastic trial head is placed on the trunnion and a trial reduction can be performed (Fig. 7c).



Fig. 7c

INFORMATION:

Depending on the final implant kink orientation, the reconstructed offset might vary from trialing off the reamer. For that reason, trialing off the reamer can only help assessing the reconstructed leg length. It is highly recommended to trial off the final stem to establish the correct offset and leg length. Depending on the bone quality the seating of the final stem might vary slightly from the reamer.



Fig. 8a



Fig. 8b



Fig. 8c

In order to determine which spacers are needed, slide the spacer gauge over the reamer shaft, so that the post of the spacer gauge is pushed up (Fig. 8a). There are two ways to read off the gauge:

1. height markings on the height gauge post align with the top of the tube (Fig. 8b)
2. height markings on the height gauge tube align with the pin (Fig. 8c)

The spacer gauge is removed and the screw in the trial neck is loosened with the screwdriver until the trial neck can be removed.

The reamer adapter and T-Handle are reattached to remove the reamer.



Fig. 9

Option 2: Impaction of implant stem

The selected stem of the MP Reconstruction System, which corresponds to the size of the last reamer, is connected to the stem adapter. The stem adapter is screwed into the thread in the proximal end of the implant stem by using the hex screwdriver (Fig. 9).

Assemble the impactor handle to the implant and stem adapter as shown in Fig. 10a.

INFORMATION:

The laser line on the implant stem marks the side of the stem with the 3° kink. It should be aligned with the laser line on the impactor handle (Fig. 10b). The markings are used for better orientation during impaction. The arrow on the strike plate now indicates where the angle of the stem is. This allows inserting the MP stem into the femoral canal precisely aligned to the natural curvature of the femur.

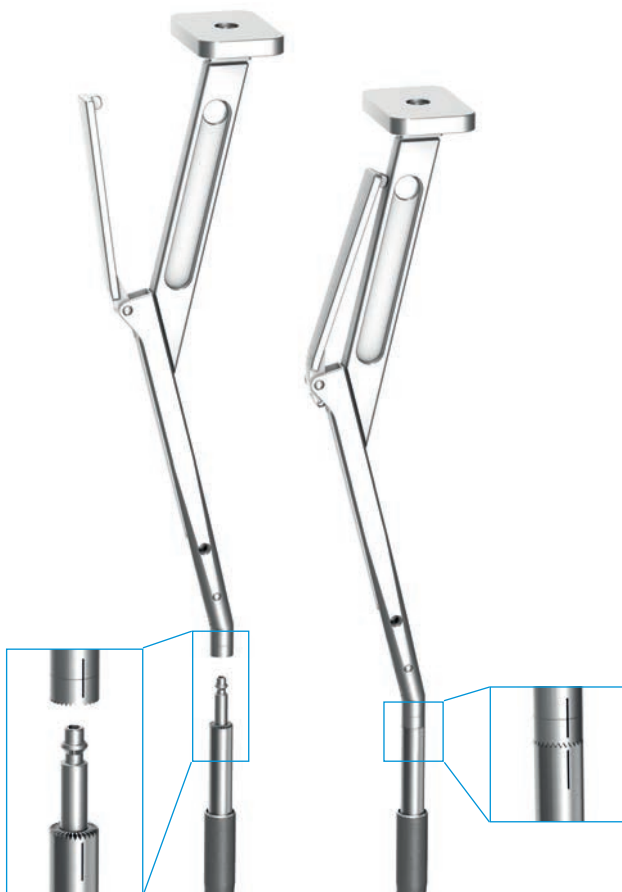

Fig. 10a

Fig. 10b

The stem is placed in the prepared femoral canal by hand until safe bony engagement is achieved and it is then driven into its definitive position with a few hammer strokes.

The stability of the fixation can be recognized in the following way:

- 1) The prosthesis penetrates deeper into the medullary cavity with each hammer stroke, until the required stability has been achieved and the prosthesis no longer moves under continued hammer strokes.
- 2) At the same time, the sound of the hammering changes to a higher pitch.

INFORMATION:

If the stem protrudes after impaction, in order to have an adequate positioning of the stem, it is recommended to remove the implant again and repeat the reaming process. This time the reaming depth should be up to 10 mm deeper than before.

The impactor handle is now removed.



Fig. 11

Preparation of the proximal femur

The reaming guide which corresponds to the planned neck segment is pushed onto the implant adapter until it is fully seated (Fig. 11).



Fig. 12

The short reaming guide is used for the long neck segments. The long reaming guide is used for the short neck segments (Fig. 12).

Neck segment	Reaming guide
short (45 mm)	long - gold
long (65 mm)	short - silver



Fig. 13

Start the reamer before touching the bone. The tubular reamer is then used on power to clear out the metaphyseal medullary space by reaming over the reaming guide until the reamer is stopped in depth by the reaming guide (Fig. 13).

INFORMATION:

In case of weak bone, care should be taken. When the short reaming guide is used and the greater trochanter does not allow for the tubular reamer to be guided on the reaming guide before touching the bone, reaming can be performed in two steps. First use the long reaming guide to clear the proximal part of the greater trochanter. The short reaming guide can then be used in a second reaming step to prepare for the neck segment in sufficient depth.

Reamer, reaming guide and stem adapter are removed.

Trialing with trial neck

Insert the guide rod into the stem using the hex screwdriver. The trial neck segment is then slid over the guide rod onto the stem either by hand or insertion forceps (Fig. 14a right).

The trial neck segment can be driven into its final position with gentle hammer strokes, using the neck inserter / screwdriver (Fig. 14a left).

If spacers are used, trial spacers are slid over the guide rod before inserting the neck segment.

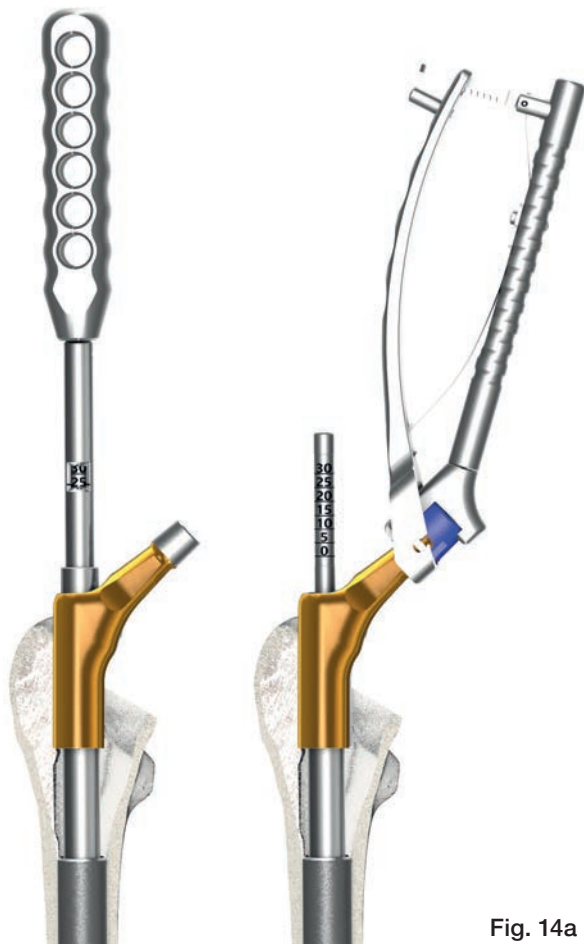

Fig. 14a

The final position of the neck segment is indicated by the scale within the window of the neck inserter / screwdriver. If the markings of the guide rod and neck inserter **touch**, the window displays the spacer height (Fig. 14b):

- if no spacer is used, the reference is the „0“ line.
- if spacers are used, the total spacer height is the reference line (e.g., for 5 mm + 10 mm spacers, the reference line is „15“).

Once the trial neck segment is in the final position, the guide rod is removed and the trial neck is fixed with a trial screw using the hex screwdriver.

Use the short trial screw with no spacers or up to +10 mm. Use the long trial screw with spacers between +15 mm and +30 mm.



Fig. 14b

Fig. 14c

Various trial heads are used to check for optimal offset, rotation, correct leg length and adequate stability. The range of motion is also checked in order to exclude any impingement of bone or implant with the acetabular cup (Fig. 14c).

The trial components are removed.

Use of proximal spacers:

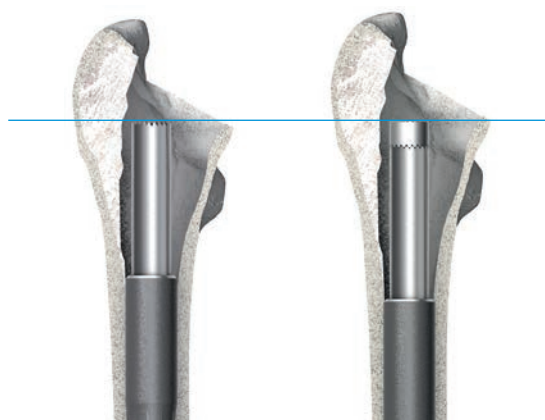

Leg length: ± 0 mm

± 0 mm

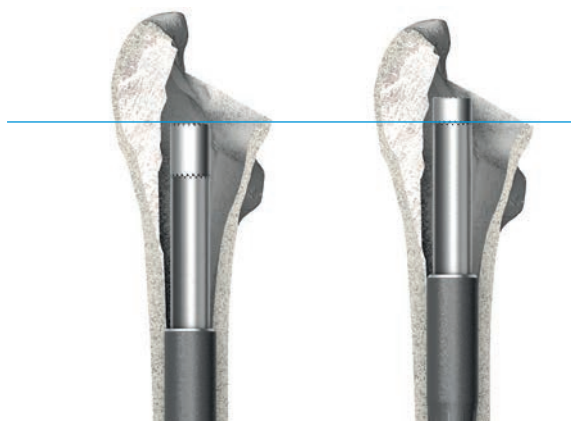

± 0 mm

+ 10 mm

Leg length and lateralization

Leg length can be corrected by 5 mm, 10 mm, 15 mm, 20 mm, 25 mm or 30 mm (or combination of any, but no more than two proximal spacers) by using trial proximal spacers.

Fine tuning of the leg length and different lateralization of the hip prosthesis stem can be achieved by selecting:

- neck segment with low (32 mm), standard (38 mm) or high (46 mm) offset with no change in leg length or
- trial head with suitable head-neck length; changing both leg length and offset

INFORMATION:

Short (45 mm) trial neck segments must not be used with more than +10 mm proximal spacers.

Anteversion of the neck segment

The anteversion can be adjusted by turning the trial neck segment after loosening the fixation screw. The desired position should then be marked on the bone so that the final neck segment can be positioned correctly.

INFORMATION:

Use a short trial fixation screw with no, 5 mm or 10 mm proximal spacers. Use a long trial fixation screw with any spacer combination longer than 10 mm.

INFORMATION:

In case the 45 mm neck segment is replaced with 65 mm neck segment, the reaming with tubular reamer may be required, due to the longer distal neck part.

In this case, please proceed as described in "Preparation of the proximal femur".

Once the leg length, anteversion and joint stability have been checked, the trial prostheses can be removed.

Implantation of neck segment

INFORMATION:

All components and interfaces must be clean before assembly

Insert the guide rod into the stem using the hex screwdriver. The neck segment is then slid over the guide rod onto the stem either by hand or insertion forceps (Fig. 15a right).

The neck segment can be driven into its final position with gentle hammer strokes, using the neck inserter / screwdriver (Fig. 15a left).

If spacers are used, they are slid over the guide rod before inserting the neck segment.

The final position of the neck segment is indicated by the scale in the neck inserter / screwdriver's window (Fig. 15b).

If the markings of the guide rod and neck inserter **touch**, the window displays the spacer height:

- if no spacer is used, the reference is the „0“ line (Fig. 15b).
- if spacers are used, the total spacer height is the reference line (e.g., for 5 mm + 10 mm spacers, the reference line is „15“).

Once the neck segment is in the final position, the guide rod is removed and the neck segment is fixed with the expansion bolt, using the neck inserter. Use the short expansion bolt with no spacers or up to +10 mm. Use the long expansion bolt with spacers between +15 mm and +30 mm.

A final trial reduction can be achieved using a plastic trial head. If necessary, the anteversion can now be adjusted by loosening the expansion bolt again. Re-insert the guide rod into the stem, then lift the neck slightly to rotate it. Then the alignment steps are repeated as described above.

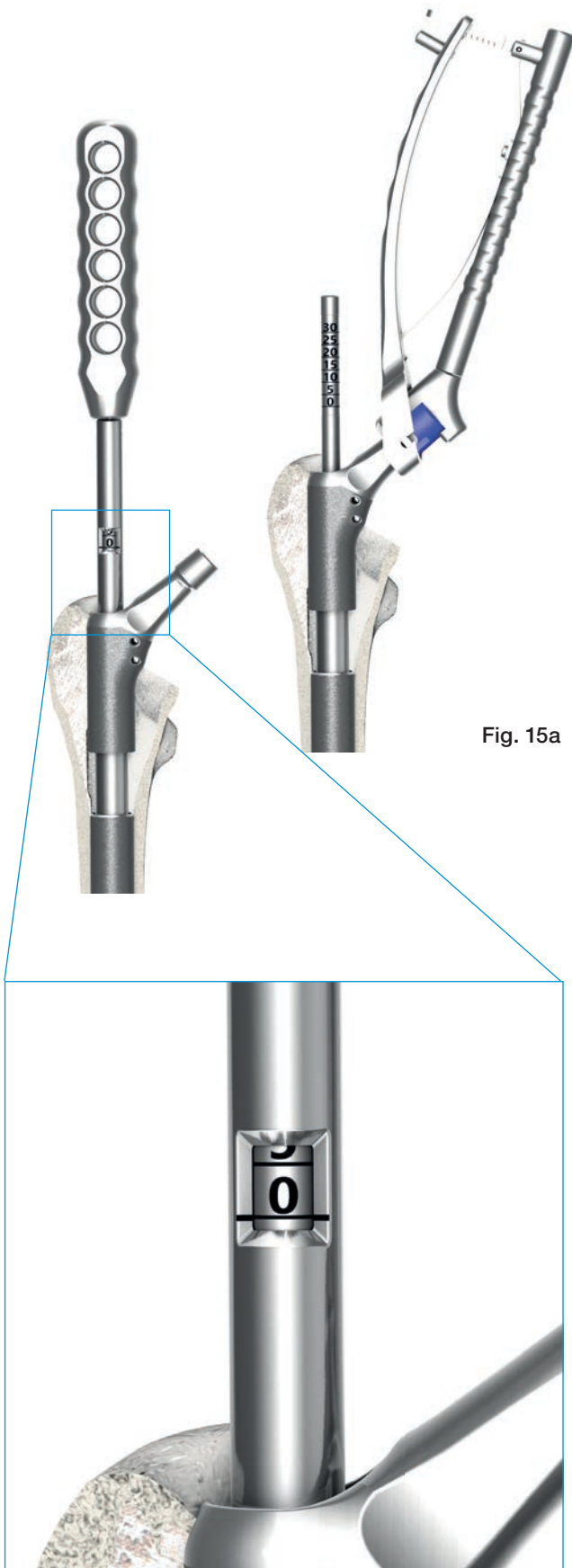

Fig. 15a

Fig. 15b



Fig. 16

Final assembly of the implant

After the expansion bolt is hand tightened with the neck inserter / screwdriver, the expansion bolt is tightened with the torque wrench. When tightening the expansion bolt with the torque wrench, the insertion forceps are used as a counter torque by gripping the neck segment over the trunnion. Once the necessary torque is reached, the torque wrench emits a loud snap (Fig. 16).

INFORMATION:

The plastic sleeves (taper caps) of the insertion forceps must be checked for damage before use.

CAUTION:

Expansion bolts can only be used once. It is not possible to reuse them because no expansion occurs when the bolt is tightened a second time.

Attaching the prosthesis head

The trunnion of the neck segment is carefully cleaned and dried. This is particularly important with ceramic heads. Then the head is attached by hand with a rotational movement, applying axial pressure. To finish, the driver is used to tap the prosthesis head into position (Fig. 17).



Fig. 17

Final reduction of the joint

After cleaning the joint surfaces, the joint is reduced. The wound is closed in layers.

Implantation of 160 mm stems

160 mm stems are only combined with 35 mm neck segments without proximal spacers. In this case the instruments for MP Modular 160 mm are necessary.

All surgical steps, except trialing off the reamer, are identical to the surgical technique described above for uncemented stems. Optionally this can be done with the low offset reamer trial neck, but note that the offset value will differ between the trial and the implant. The reamer trial neck does not provide an accurate leg length assessment.

For the proximal femur preparation, the long silver reaming guide 134-205/35 is used. When using the insertion forceps, replace taper cap 179-122/01 with 131-830/04.



Fig. 18



Fig. 19

Surgical Technique, cemented

Procedure

For cemented stem implantation the 180 mm MP trial stems (134-070/00), the additional instrument set for the cemented surgical technique (134-346/00), and a UHMWPE insertion sleeve (134-212/00) are required in addition to the basic instrument set.

The medullary canal is prepared with the standard reamers. It is recommended to start with the smallest diameter and open up the medullary canal millimeter by millimeter until contact with the cortical bone is reached distally around the circumference.

For a 1 mm cement coating, the medullary cavity must be reamed at least 2 mm wider than the stem diameter.

It might be necessary to clear the proximal femur to insert the plastic sleeve. If this can not be achieved using the start reamer, please proceed with the following steps.

Once the medullary space has been prepared to the required diameter, select a 180 mm trial stem corresponding to the last reamer diameter.

The trial stem is secured to the inserter using the hex screwdriver, and then inserted into the femur up to the planned proximal marking (Fig. 18).

CAUTION:

Do not exert too much pressure, as the trial stem is not intended to achieve a press fit, and can thus be driven further into the femur than planned.

The stem adapter (134-202/02) is screwed onto the trial stem. The reaming guide that corresponds to the neck segment used is pushed onto the implant adapter until it is seated. Then the proximal bone is reamed away for the cemented preparation with the tubular reamer (134-211/00) (Fig. 19).

Remove the reamer guide, stem adapter and take out the trial stem using the inserter. If needed, use the slap hammer.

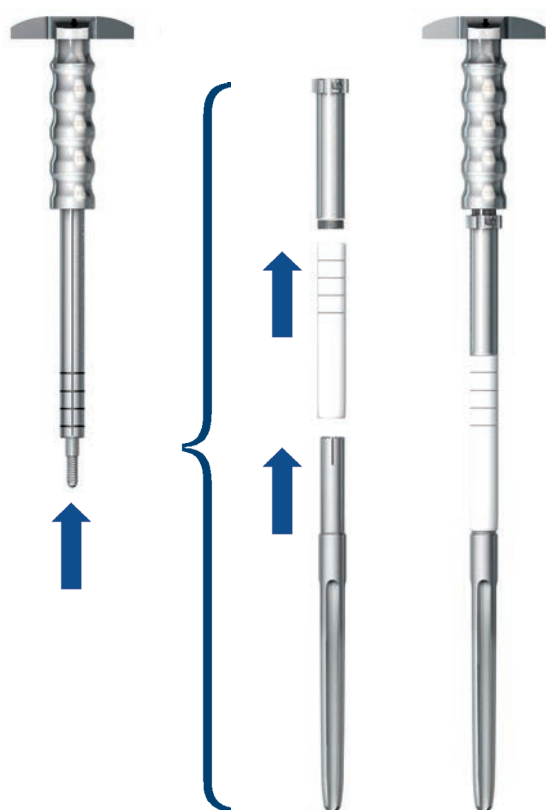

Fig. 20

The plastic sleeves must be checked for damage before use.

The plastic sleeve is screwed to the insertion sleeve, pushed onto the proximal section of the implant stem, and then screwed to the inserter (Fig. 20).

The medullary cavity is then sealed with a bone dowel or a medullary plug a little below the intended position of the stem tip. Following application of the cement, the hip prosthesis stem is introduced into the medullary space. The markings on the plastic sleeve correspond to the markings on the inserter used in the uncemented surgical technique. As such, the lowest line on a plastic sleeve marks the proximal end of the stem.

CAUTION:
When applying the cement, it is essential to ensure secure fixation of the distal end of the stem. Proximal oozing of the cement should be avoided and any escaping cement removed before it sets.



Fig. 21

The stem is held in the required position with the inserter until the cement sets. The plastic sleeve prevents excess cement from coming into contact with the proximal portion of the stem (Fig. 21). Once the cement has completely set, the inserter is disconnected from the implant and removed along with the plastic sleeve.



To remove the plastic sleeve, the extractor is inserted in the sleeve and the bayonet mount is locked. The plastic sleeve can now be twisted free from the cement and removed (Fig. 22).

The implant adapter is screwed onto the prosthesis stem and the further preparation of the proximal femur can continue as shown on page 09.

Any excess cement is then removed from the proximal femur at the next reaming stage with the tubular reamer (134-211/00).

INFORMATION:

Radioscopic control is recommended to check the cement application and prosthesis positioning.

Fig. 22

Hip Prosthesis Stems, uncemented

MAT Tilastan-S (Ti6Al4V)



REF microporous	Prox. stem-Ø mm	Dist. stem-Ø mm	Length mm
172-916/14	14.0	12.0	160
172-916/16	16.0	14.0	160
172-916/18	18.0	16.0	160
172-916/20	20.0	18.0	160
172-916/22	22.5	21.0	160
172-916/25	25.0	23.0	160
172-918/12	12.0	10.0	180
172-918/14	14.0	12.0	180
172-918/16	16.0	14.0	180
172-918/18	18.0	16.0	180
172-918/20	20.0	18.0	180
172-918/22	22.5	21.0	180
172-918/25	25.0	23.0	180
172-921/12	12.0	10.0	210
172-921/14**	14.0	12.0	210
172-921/16	16.0	14.0	210
172-921/18	18.0	16.0	210
172-921/20	20.0	18.0	210
172-921/22	22.5	21.0	210
172-921/25	25.0	23.0	210
172-925/14*	14.0	11.0	250
172-925/16	16.0	13.0	250
172-925/18	18.0	15.0	250
172-925/20	20.0	17.0	250
172-925/22	22.5	19.0	250
172-925/25	25.0	22.0	250
172-929/14*	14.0	9.0	290
172-929/16	16.0	11.0	290
172-929/18	18.0	13.0	290
172-929/20	20.0	15.0	290
172-929/22	22.5	18.0	290
172-929/25	25.0	20.0	290
172-930/14*	14.0	8.0	330
172-930/16	16.0	10.0	330
172-930/18	18.0	12.0	330
172-930/20	20.0	14.0	330
172-930/22	22.5	16.0	330
172-930/25	25.0	19.0	330

INFORMATION:

Use 160 mm stems only with 35 mm neck segments and without proximal spacers.

Do not use 210 mm / Ø12 mm stems with proximal spacers.

*** CAUTION:**

Stems with a neck/head combination exceeding 40 mm offset could not be proven meet mechanical normatives.

**** CAUTION:**

Do not use proximal spacers with L or XL heads if the neck offset is 40 mm or more.

Hip Prosthesis Stems, cemented

MAT EndoDur-S (CoCrMo alloy)

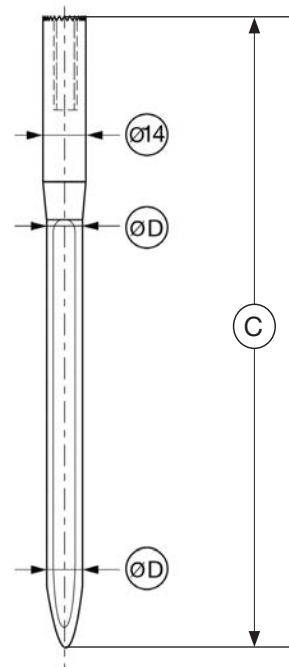

REF	for stem length (C) mm	Stem Ø (D) mm
172-900/12	200	12
172-900/14	200	14
172-900/16	200	16
172-901/12	240	12
172-901/14	240	14
172-901/16	240	16
172-902/12	280	12
172-902/14	280	14
172-902/16	280	16
172-903/12	320	12
172-903/14	320	14
172-903/16	320	16

CAUTION:

Stems 240 mm or longer with a neck/head offset over 43.2 mm could not be proven meet mechanical normatives.

Neck Segments

MAT Tilastan , Taper 12/14 mm



REF	Description	Length mm	Version	CCD angle	Offset mm
172-965/26	Neck Segment, standard	35	short	126°	31
172-965/35	Neck Segment, standard	35	short	135°	29
172-981/26*	Neck Segment, XXL	35	short	126°	40
172-981/35*	Neck Segment, XXL	35	short	135°	40



REF	Description	Length mm	Version	CCD angle	Offset mm
99-0984/32	Neck Segment with suture holes, standard	35	short	126°	31
99-0984/28*	Neck Segment with suture holes, XXL	35	short	126°	40



REF	Description		Length mm	Version	CCD angle	Offset mm
137-045/32	Neck Segment, low offset	Slim	45	short	136°	32
137-045/38	Neck Segment, standard	Slim	45	short	131°	38
137-065/38	Neck Segment, standard	Slim	65	long	131°	38
137-065/46*	Neck Segment, lateralized	Slim	65	long	126°	46
137-145/38	Neck Segment, standard	Defect Reconstruction	45	short	131°	38
137-165/38	Neck Segment, standard	Defect Reconstruction	65	long	131°	38
137-165/46*	Neck Segment, lateralized	Defect Reconstruction	65	long	126°	46

*** CAUTION:**

Do NOT use with L or XL heads together with stems 250 mm / Ø14 mm, 290 mm / Ø14 mm or 330 mm / Ø14 mm

Proximal Spacers

MAT EndoDur-S (CoCrMo alloy)



REF	Description	Length mm
172-950/05	Proximal Spacer	5
172-950/10	Proximal Spacer	10
172-950/20	Proximal Spacer	20

Expansion Bolts

MAT EndoDur-S (CoCrMo alloy)



REF	Description	SW mm	Length mm
172-947/38	Expansion Bolt	8	41
172-947/58	Expansion Bolt	8	61

Offset- and length values using different neck segments and heads

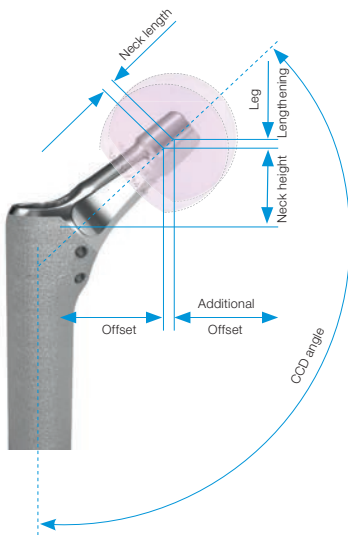

	CCD angle 136° Head Ø 28 - 40 mm size M	CCD angle 131° Head Ø 28 - 40 mm size M	CCD angle 126° Head Ø 28 - 40 mm size M
Offset	32 mm	38 mm	46 mm
Neck height	33 mm	33 mm	33 mm

	CCD angle 136° Offset 32 mm Head Ø 28mm				CCD angle 131° Offset 38 mm Head Ø 28mm				CCD angle 126° Offset 46 mm Head Ø 28mm			
	S	M	L	XL	S	M	L	XL	S	M	L	XL
Additional offset	-3.5	0	+3,5	+10.5	-3.5	0	+3,5	+10.5	-3.5	0	+3,5	+10.5
	29.6	32	34.4	39.3	35.4	38	40.6	45.9	43.2	46	48.8	54.5
Leg lengthening	-2.4	0	2.4	7.3	-2.6	0	2.6	7.9	-2.8	0	2.8	8.5
	-2.5	0	2.5	7.5	-2.3	0	2.3	6.9	-2.1	0	2.1	6.2

	CCD angle 136° Offset 32 mm Head Ø 32-36mm				CCD angle 131° Offset 38 mm Head Ø 32-36mm				CCD angle 126° Offset 46mm Head Ø 32-36mm			
	S	M	L	XL	S	M	L	XL	S	M	L	XL
Additional offset	-4	0	+4	+8	-4	0	+4	+8	-4	0	+4	+8
	-2.8	0	2.8	5.6	-3.0	0	3.0	6.0	-3.2	0	3.2	6.5
Leg lengthening	29.2	32	34.8	37.6	35.0	0	41.0	44.0	42.8	46	49.2	52.5
	-2.9	0	2.9	5.8	-2.6	0	2.6	5.3	-2.4	0	2.4	4.7

Compatibility between neck segments, proximal spacers and expansion bolts

Spacer mm	Expansion bolt	Neck segment	Offset mm
0	short	short (45 mm) or long (65 mm)	32, 38, 46
5	short	short (45 mm) or long (65 mm)	32, 38, 46
10	short	short (45 mm) or long (65 mm)	32, 38, 46
15	long	long (65 mm)	38, 46
20	long	long (65 mm)	38, 46
25	long	long (65 mm)	38, 46
30	long	long (65 mm)	38, 46

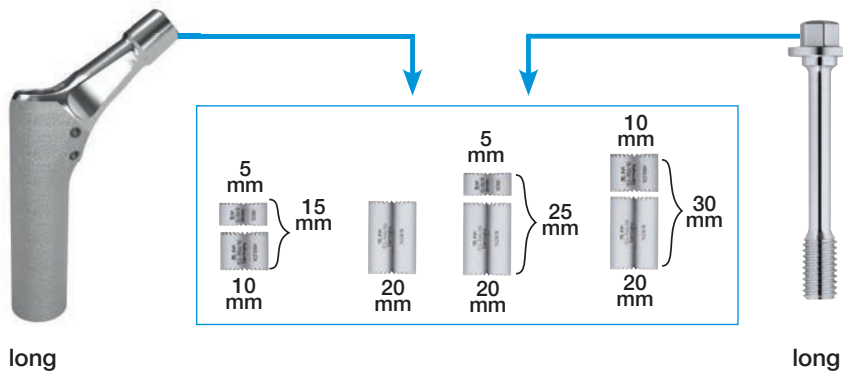
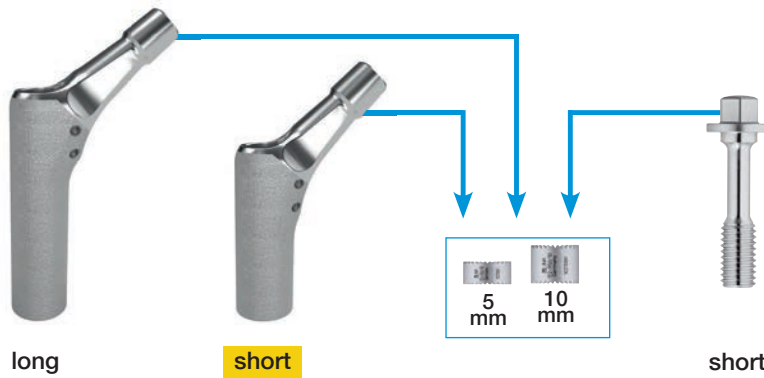

Neck segment	Reaming guide
short (35 mm)	long - silver
short (45 mm)	long - gold
long (65 mm)	short - silver

Use 160 mm stems only with 35 mm neck segments and without proximal spacers.

134-341/00 MP General Instruments

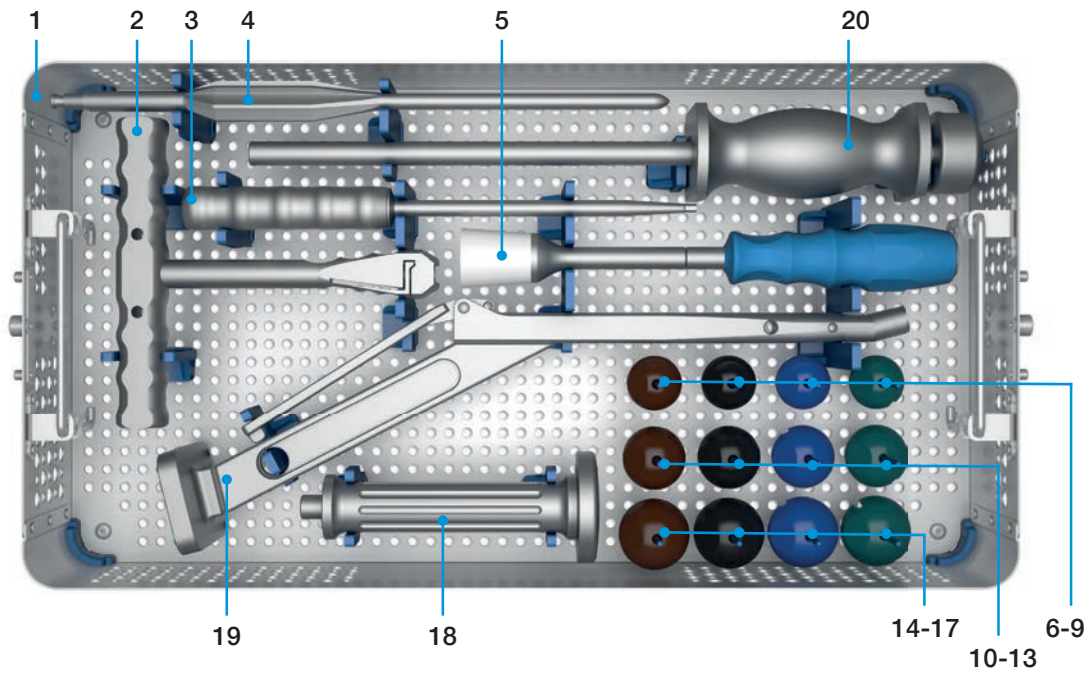

	REF	Description		
1	134-341/01	MP General Instruments, empty		
2	15-6053/00	T-handle		
3	136-203/00	Hex Screwdriver		
4	136-200/00	Proximal Start Reamer		
5	175-360	Head Impactor		
6	175-928/11	Trial Head	28 mm	s
7	175-928/12	Trial Head	28 mm	m
8	175-928/13	Trial Head	28 mm	l
9	175-928/14	Trial Head	28 mm	xl
10	175-932/11	Trial Head	32 mm	s
11	175-932/12	Trial Head	32 mm	m
12	175-932/13	Trial Head	32 mm	l
13	175-932/14	Trial Head	32 mm	xl
14	175-936/11	Trial Head	36 mm	s
15	175-936/12	Trial Head	36 mm	m
16	175-936/13	Trial Head	36 mm	l
17	175-936/14	Trial Head	36 mm	xl
18	136-210/01	Detachable Handle		
19	136-210/00	Stem Inserter		
20	317-661	Slap Hammer		

134-342/00 MP Modular Basic Instruments

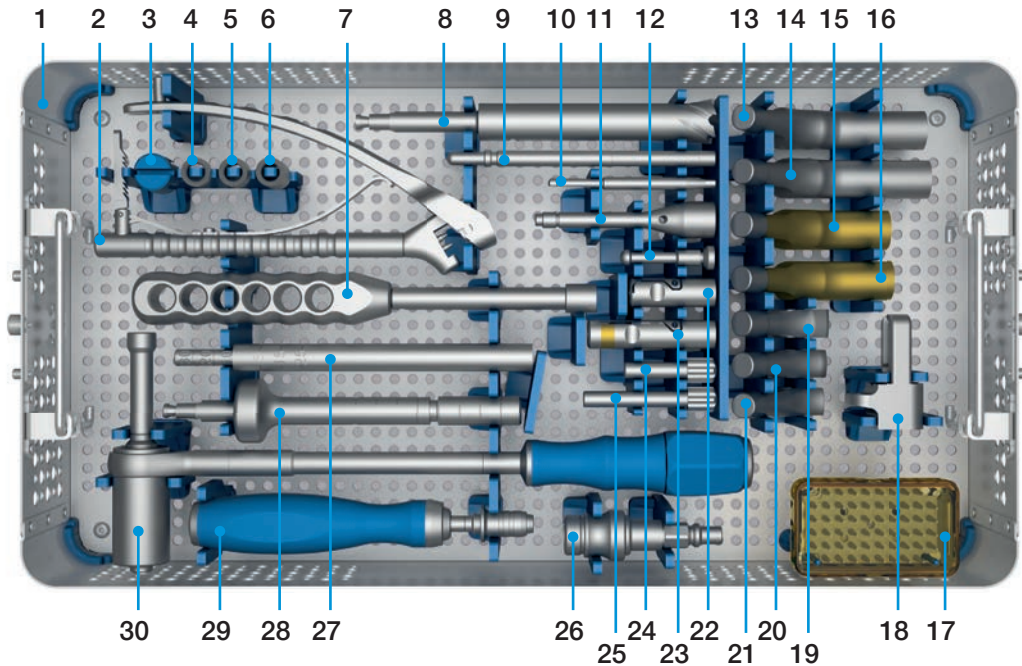

	REF	Description		
1	134-342/01	MP Modular Basic Instruments, empty		
2	179-122	Insertion Forceps		
3	179-122/01	Taper Cap		
4	131-398/05	Trial Spacer	5 mm	
5	131-398/10	Trial Spacer	10 mm	
6	131-398/20	Trial Spacer	20 mm	
7	134-216/00	Screwdriver / Neck Inserter	hex 8 mm	
8	134-217/00	Tubular Reamer		
9	134-215/00	Guide Rod		
10	134-220/02	Hex Screwdriver, 3.5mm	modular	
11	134-202/03	Implant Extractor		
12	134-202/06	Neck Extractor Bolt		
13	134-219/46	Trial Neck	lateralized	long
14	134-219/38	Trial Neck	standard	long
15	134-218/38	Trial Neck	standard	short
16	134-218/32	Trial Neck	low offset	short
17	319-601/30	Sterilizing Box, contains:		
	134-220/01	Screws for Reamer Trial Neck, 3 pcs.		
	134-202/02	Stem Adapter		
18	134-202/04	Neck Extractor Base		
19	134-220/32	Reamer Trial Neck	low offset	
20	134-220/38	Reamer Trial Neck	standard	
21	134-220/46	Reamer Trial Neck	lateralized	
22	134-205/65	Reaming Guide for 65 mm neck segments		
23	134-205/45	Reaming Guide for 45 mm neck segments		
24	134-100/41	Trial Screw	short	
25	134-100/61	Trial Screw	long	
26		Adapter, optional		
	16-3283/01	Adapter Hudson female / Jacobs male		
	16-3284/00	Adapter Hudson female / AO male		
	16-3286/00	Adapter Hudson female / Harris male		
27	134-220/04	Spacer Gauge		
28	134-501/01	Reamer Driver Adapter		
29	134-220/03	Torque Limiting Handle	3 Nm	
30	134-140/00	Torque Wrench	hex 8 mm	

134-343/00 MP Reamers Core Lengths

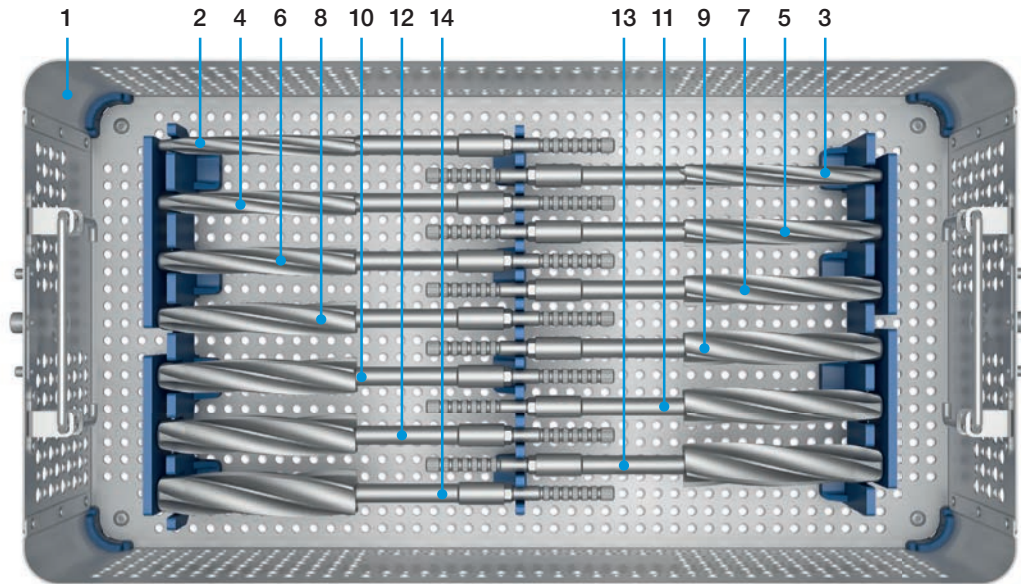

	REF	Description		
1	134-343/01	MP Reamers core lengths, empty		
2	134-518/12	Reamer, modular	12 mm	180 mm
3	134-518/13	Reamer, modular	13 mm	180 mm
4	134-518/14	Reamer, modular	14 mm	180 mm
5	134-518/15	Reamer, modular	15 mm	180mm
6	134-518/16	Reamer, modular	16mm	180 mm
7	134-518/17	Reamer, modular	17 mm	180 mm
8	134-518/18	Reamer, modular	18 mm	180 mm
9	134-518/19	Reamer, modular	19 mm	180 mm
10	134-518/20	Reamer, modular	20 mm	180 mm
11	134-518/21	Reamer, modular	21 mm	180 mm
12	134-518/01	Reamer, modular	22.5 mm	180 mm
13	134-518/24	Reamer, modular	24 mm	180 mm
14	134-518/25	Reamer, modular	25 mm	180 mm

134-343/00 MP Reamers Core Lengths

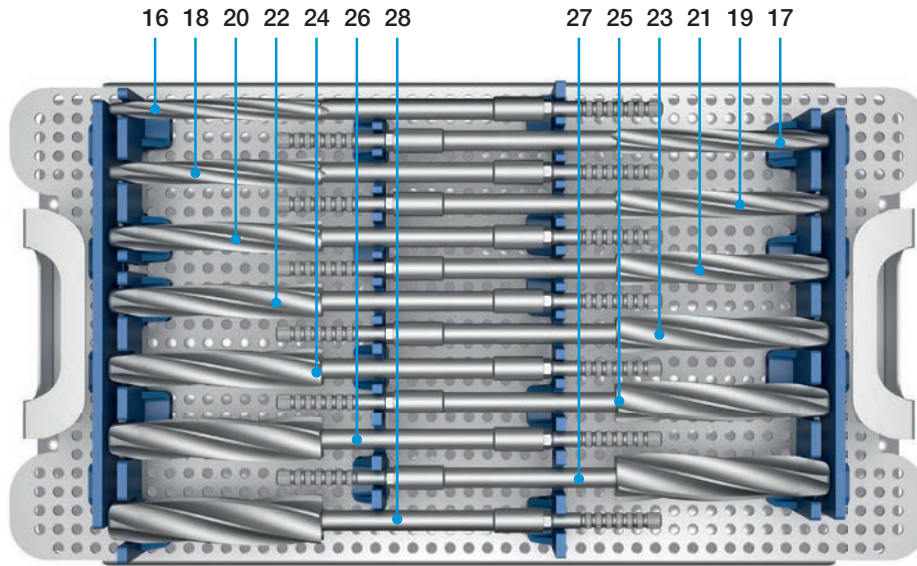

	REF	Description		
		MP Reamers core lengths, empty		
16	134-521/12	Reamer, modular	12 mm	210 mm
17	134-521/13	Reamer, modular	13 mm	210 mm
18	134-521/14	Reamer, modular	14 mm	210 mm
19	134-521/15	Reamer, modular	15 mm	210 mm
20	134-521/16	Reamer, modular	16 mm	210 mm
21	134-521/17	Reamer, modular	17 mm	210 mm
22	134-521/18	Reamer, modular	18 mm	210 mm
23	134-521/19	Reamer, modular	19 mm	210 mm
24	134-521/20	Reamer, modular	20 mm	210 mm
25	134-521/21	Reamer, modular	21 mm	210 mm
26	134-521/01	Reamer, modular	22.5 mm	210 mm
27	134-521/24	Reamer, modular	24 mm	210 mm
28	134-521/25	Reamer, modular	25 mm	210 mm

134-344/00 MP Modular 160 mm

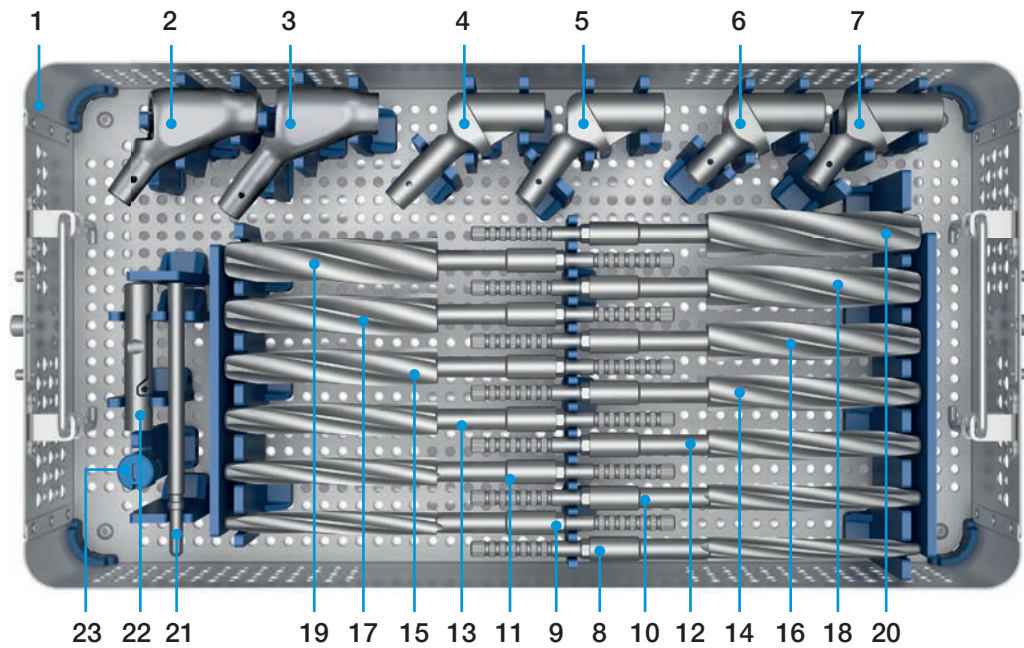

	REF	Description		
1	134-344/01	MP Modular 160 mm, empty		
2	99-0984/33	Trial Neck, with suture holes	35 mm	126°
3	99-0984/29	Trial Neck XXL, with suture holes	35 mm	126°
4	131-393/35	Trial Neck XXL	35 mm	135°
5	131-393/26	Trial Neck XXL	35 mm	126°
6	131-395/26	Trial Neck	35 mm	126°
7	131-395/35	Trial Neck	35 mm	135°
8	134-516/12	Reamer, modular	12 mm	160 mm
9	134-516/13	Reamer, modular	13 mm	160 mm
10	134-516/14	Reamer, modular	14 mm	160 mm
11	134-516/15	Reamer, modular	15 mm	160 mm
12	134-516/16	Reamer, modular	16 mm	160 mm
13	134-516/17	Reamer, modular	17 mm	160 mm
14	134-516/18	Reamer, modular	18 mm	160 mm
15	134-516/19	Reamer, modular	19 mm	160 mm
16	134-516/20	Reamer, modular	20 mm	160 mm
17	134-516/21	Reamer, modular	21 mm	160 mm
18	134-516/01	Reamer, modular	22.5 mm	160 mm
19	134-516/24	Reamer, modular	24 mm	160 mm
20	134-516/25	Reamer, modular	25 mm	160 mm
21	134-215/01	Guide Rod, short for MP stem D12 mm only		160 mm
22	134-205/35	Reaming Guide for 35 mm neck segment		
23	131-830/04	Taper Cap		

134-345/00 MP Reamers Long Stems

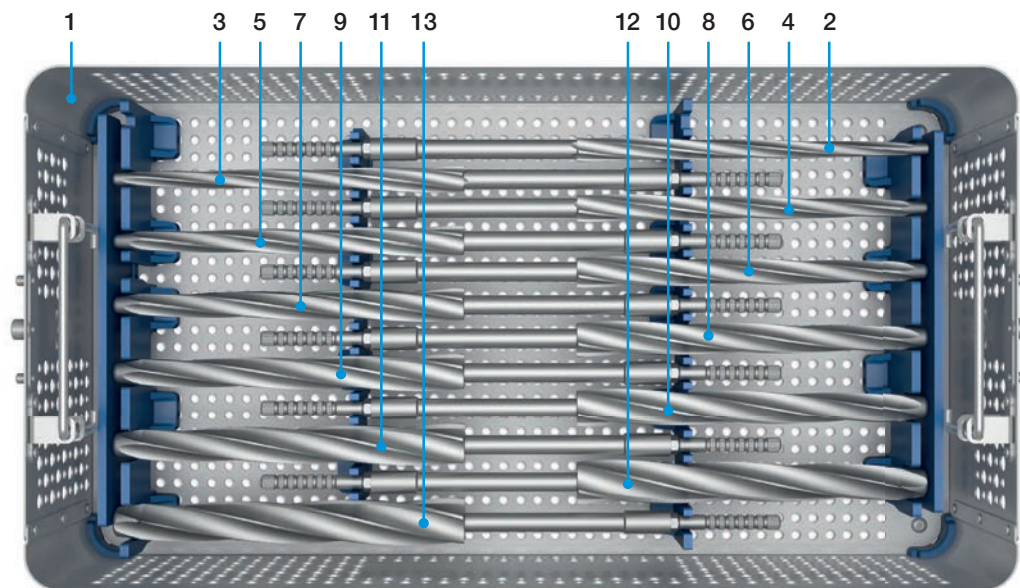

	REF	Description		
1	134-345/01	MP Reamers Long Stems, empty		
2	134-529/13	Reamer, modular	13 mm	290 mm
3	134-529/14	Reamer, modular	14 mm	290 mm
4	134-529/15	Reamer, modular	15 mm	290 mm
5	134-529/16	Reamer, modular	16 mm	290 mm
6	134-529/17	Reamer, modular	17 mm	290 mm
7	134-529/18	Reamer, modular	18 mm	290 mm
8	134-529/19	Reamer, modular	19 mm	290 mm
9	134-529/20	Reamer, modular	20 mm	290 mm
10	134-529/21	Reamer, modular	21 mm	290 mm
11	134-529/01	Reamer, modular	22.5 mm	290 mm
12	134-529/24	Reamer, modular	24 mm	290 mm
13	134-529/25	Reamer, modular	25 mm	290 mm

134-345/00 MP Reamers Long Stems

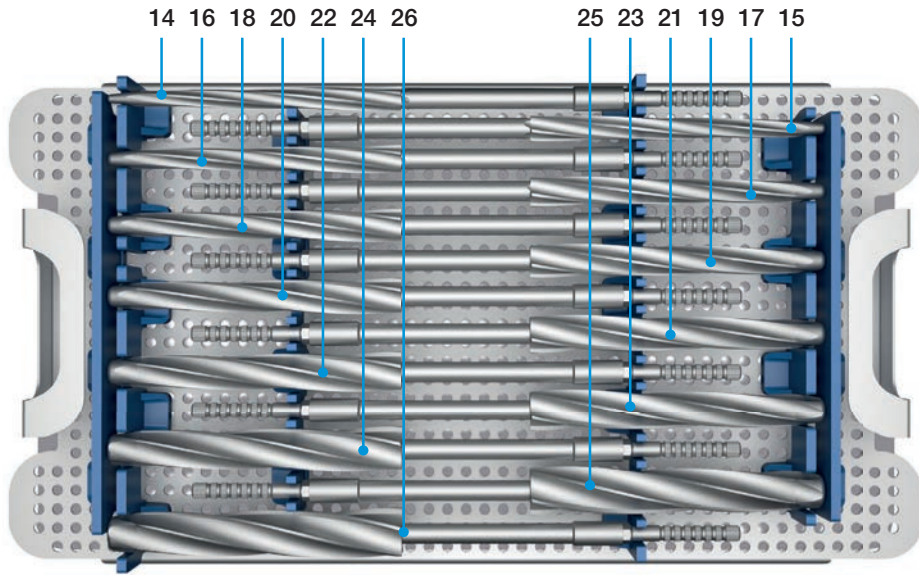

	REF	Description		
		MP Reamers Long Stems, empty		
14	134-525/12	Reamer, modular	12 mm	250 mm
15	134-525/13	Reamer, modular	13 mm	250 mm
16	134-525/14	Reamer, modular	14 mm	250 mm
17	134-525/15	Reamer, modular	15 mm	250 mm
18	134-525/16	Reamer, modular	16 mm	250 mm
19	134-525/17	Reamer, modular	17 mm	250 mm
20	134-525/18	Reamer, modular	18 mm	250 mm
21	134-525/19	Reamer, modular	19 mm	250 mm
22	134-525/20	Reamer, modular	20 mm	250 mm
23	134-525/21	Reamer, modular	21 mm	250 mm
24	134-525/01	Reamer, modular	22.5 mm	250 mm
25	134-525/24	Reamer, modular	24 mm	250 mm
26	134-525/25	Reamer, modular	25 mm	250 mm

134-351/00 MP Reamers 330 mm

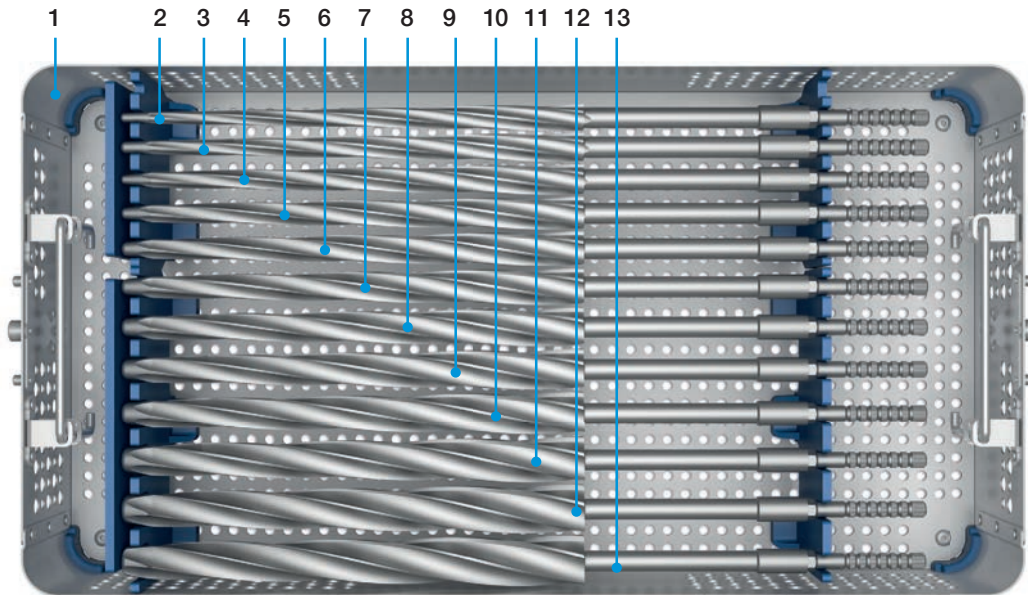

	REF	Description		
1	134-351/01	MP Reamers 330 mm, empty		
2	134-533/13	Reamer, modular	13 mm	330 mm
3	134-533/14	Reamer, modular	14 mm	330 mm
4	134-533/15	Reamer, modular	15 mm	330 mm
5	134-533/16	Reamer, modular	16 mm	330 mm
6	134-533/17	Reamer, modular	17 mm	330 mm
7	134-533/18	Reamer, modular	18 mm	330 mm
8	134-533/19	Reamer, modular	19 mm	330 mm
9	134-533/20	Reamer, modular	20 mm	330 mm
10	134-533/21	Reamer, modular	21 mm	330 mm
11	134-533/01	Reamer, modular	22.5 mm	330 mm
12	134-533/24	Reamer, modular	24 mm	330 mm
13	134-533/25	Reamer, modular	25 mm	330 mm

134-346/00 MP Modular Cemented Stems

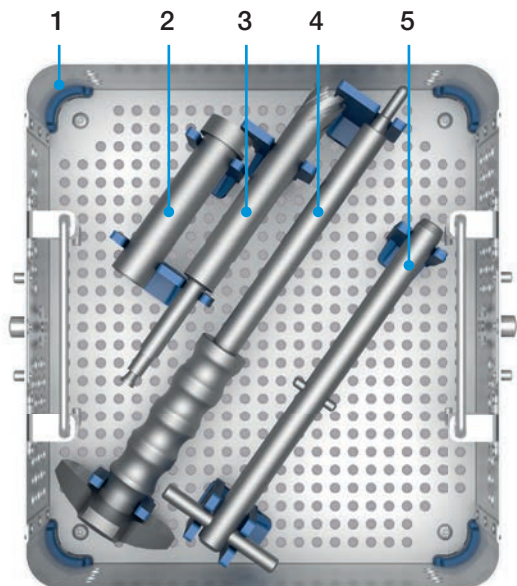

	REF	Description
1	134-346/01	MP Modular Cemented Stems, empty
2	134-213/00	Insertion Sleeve
3	134-211/00	Tubular Reamer
4	134-210/00	Stem Impactor
5	134-214/00	Extractor

	REF	Description
	134-212/00	Insertion Sleeve for Cemented Stems

134-350/00 Extraction Instruments

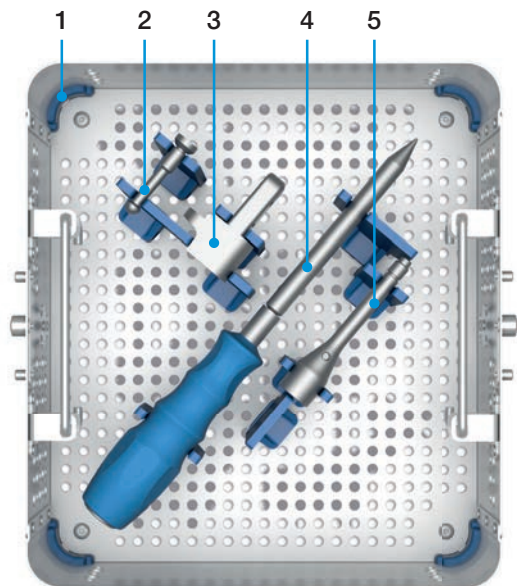

	REF	Description
1	134-350/01	Extraction Instruments, empty
2	134-202/06	Neck Extractor Bolt
3	134-202/04	Neck Extractor Base
4	134-202/05	Extraction Plunger
5	134-202/03	Implant Extractor

X-ray Templates

110% natural size

(X-ray templates 120% natural size available on request)

REF	Description	Type	Offset
134-516/77	160 mm Stems	uncemented	
134-518/77	180 mm Stems	uncemented	
134-521/77	210 mm Stems	uncemented	
134-525/77	250 mm Stems	uncemented	
134-529/77	290 mm Stems	uncemented	
134-533/77	330 mm Stems	uncemented	
134-520/77	200 mm Stems	cemented	
134-524/77	240 mm Stems	cemented	
134-528/77	280 mm Stems	cemented	
134-532/77	320 mm Stems	cemented	
134-555/77	Neck Segments	slim	low, standard, high
134-555/78	Neck Segments	defect reconstruction	standard, high

Cleaning and Care Instructions

Corresponding instructions for the instrument sets are available from info@link-ortho.com on request.

Reprints

Ph. Lubinus, W. Klauser

The Revision Femur: A Potpourri of Options, A Modular Option for Proximal Bone Loss, Orthopaedics, Vol. 23 No. 9, Sept. 2000 ([H112](#))

A. Seth Greenwald, Paul D. Postak

The Influence of Modularity on the Endurance Performance of the LINK MP Hip Stem, Orthopaedic Research Laboratories, Cleveland, Ohio, Feb. 2001 ([H114](#))

F. Bellomo, L. Bertignone, L. Morino, P. Milano, E. Schiavone, M. Barale

LINK MP cementless distal fixation modular prosthesis for revision total hip arthroplasty, J Orthopaed Traumatol (2002) 2:121-124 ©Springer Verlag 2002 ([H118](#))

Daniel J. Berry, MD

Femoral Revision, Distal Fixation With Fluted, Tapered Grit-Blasted Stems
The Journal of Arthroplasty, Vol. 17 No. 4 Suppl 1, June 2002 ([H121](#))

Louis M. Kwong, MD, A. John Miller, MD, and Philipp Lubinus, MD

A Modular Distal Fixation Option for Proximal Bone Loss in Revision Total Hip Arthroplasty, A 2- to 6- Year Follow-up Study, The Journal of Arthroplasty Vol.18 No. 3 Suppl.1 March 2003 ([H122](#))

Daniel J. Berry, MD

Treatment of Vancouver B3 Periprosthetic Femur Fractures With a Fluted Tapered Stem, Clinical Orthopaedics, No. 417, December 2003, pp. 224-231 ([H128](#))

W. Klauser, P. Lubinus

MP-Rekonstruktionsprothese (LINK), Modulare Revisionsendoprothetik des Hüftgelenks, Sonderdruck aus P. Thümler, R. Forst /Hrsg), Seiten 264-270, Springer-Verlag Berlin Heidelberg, 2004 ([H130](#))

Stephen B. Murphy, MD, and Jose Rodriguez, MD

Revision Total Hip Arthroplasty With Proximal Bone Loss,
The Journal of Arthroplasty Vol.19; No. 4; Suppl 1; June 2004 ([H133](#))

Scott M. Sporer, MD, MS; Wayne G. Paprovsky, MD, FACS

Femoral Fixation in the Face of Considerable Bone Loss, Clinical Orthopaedics, No. 429, pp 227-231, 2004

Clinical Cases with the LINK MP Hip System

Order No.: 664So/4.99L

G.S. Tamvakopoulos, C.T.J. Servant, G. Clark, J.P. Ivory

Medium-term follow-up series using a modular distal fixation prosthesis to address proximal femoral bone deficiency in revision total hip arthroplasty. A 5- to 9-years follow-up study, Hip International Vol.17 no. 3; 2007 - pp. 143-149 ([H152](#))

J.A. Rodriguez MD, R. Fada MD, S.B. Murphy MD, V.J. Rasquinha MD, C.S. Ranawat MD

Two-Year to Five-Year Follow-Up of Femoral Defects in Femoral Revision Treated with the Link MP Modular Stem, The Journal of Arthroplasty Vol.24 no. 5; August 2009 ([H156](#))

R.J. Weiss, F. Strömwall, M.O. Beckmann, K.A. Hansson, A. Stark

Distal femoral stem-bone anchorage of a cementless revision total hip arthroplasty
Acta Orthopaedica 80 (3): 298-302; 2009 ([H160](#))

M.D. Schofer, T. Efe, T.J. Heyse, N. Timmesfeld, R. Velte, F. Hinrichs, J. Schmitt

Zementfreier Femurschaftwechsel mit einem modularen Hüftendoprothesenrekonstruktionsschaft
Der Orthopäde, Bd 39, Heft 2: Februar 2010 ([H162](#))

R.J. Weiss MD PhD, M.O. Beckmann MD, † A. Enocson MD, ‡ A. Schmalholz MD PhD, ‡ A. Starck MD PhD

Minimum 5-Year Follow-Up of a Cementless, Modular, Tapered Stem in Hip Revision Arthroplasty
The Journal of Arthroplasty, Vol. 26, No. 1; 2011 ([H169](#))

R.R. Thakur MD, A.J. Deshmukh MD, A.Goyal MD, A.S. Ranawat MD, V.J. Rasquinha MD, J.A. Rodriguez MD

Management of Failed Trochanteric Fracture Fixation With Cementless Modular Hip Arthroplasty
Using a Distally Fixing Stem, The Journal of Arthroplasty, Vol. 26, No. 3; 2011 ([H170](#))

W. Klauser MD, Y. Bangert MD, P. Lubinus MD, † D. Kendoff MD

Medium-Term Follow-Up of a Modular Tapered Noncemented Titanium Stem in Revision Total Hip Arthroplasty: A Single-Surgeon Experience
The Journal of Arthroplasty, In Press, Corr. Proof, Av. online 19 Oct 2012 ([H174](#))

Additional Literature



 For more information please register for our LINK Media Library (link-ortho.com)

Please note the following regarding the use of our implants:

Follow the instructions for use!

For detailed product information, including indications and contraindications, precautions and warnings, etc. please consult the product's Instructions For Use (IFU) prior to use.



eifu.link-ortho.com

Waldemar Link GmbH & Co. KG, Hamburg, Germany

All content in this catalog, including text, pictures and data, is protected by law. Every instance of use, whether in part or in whole or which is not permitted by law, is subject to our prior consent. This applies in particular to the reproduction, editing, translation, publishing, saving, processing, or passing on of content stored in databases or other electronic media and systems, in any manner or form. The information in the catalogs is intended solely to describe the products and does not constitute a guarantee.

The Surgical Technique document described has been written to the best of our knowledge and belief, but it does not relieve the surgeon of their responsibility to duly consider the particularities of each individual case.

Products shown in this document may not be available in your country. The product availability is subject to the approval and/or registration regulations of the respective country. Please contact Waldemar Link GmbH & Co. KG if you have questions about the availability of LINK products in your country.

Waldemar Link GmbH & Co. KG and/or other corporate affiliated entities own, use or have applied for the following trademarks in many jurisdictions: LINK, BiMobile, BiPorEx, C.F.P., customLINK, directLINK, E-Dur, EndoDur, Endo-Model, Endo-Model SL, FlexiCones, GEMINI SL, HX, LCU, LINK Embrace, LINK Endo-Model EVO, LINK OptiStem, LINK PorEx, LinkSymphoKnee, MEGASYSTEM-C, MIT-H, MobileLink, Model Lubinus, MP, PlasmaLink, PorEx-Z, PoroLink, RescueSleeve, SPII, SP-CL, SPAR-K, TiCaP, Tilastan, Toolbox, T.O.P., TrabecuLink, VACUCAST, X-LINKed.

Other trademarks and trade names may be used in this document to refer to either the entities claiming the marks and/or names or their products and are the property of their respective owners.

